



H301-MINI

Compatible with the following XY stages

- Physik Instrumente: P-737.1SL/2SL/5SL
- Ludl 99A600
- It fits in any MW plate holder

Compatible with the following Okolab Controllers

- H301-T-BL-PLUS
- UNO-T
- UNO-T-H-PREMIXED
- UNO-T-H-CO2
- H401-T-DUAL

Index

1.	Components and dimensions.....	3
2.	Sample Holders.....	4
2.1	Available Sample Holders	4
3.	Insertion of the Sample Feedback Temperature Sensor	4
4.	Insertion of Sample Holder into Chamber	5
5.	Working with 35 or 60 mm Petri Dish - Spacing Rings and Magnetic Locks	5
6.	Working with 1x3'' and 1x2'' chamber slides - magnetic locks.....	7
7.	Connection of the Gas Supply	8
8.	Working with Perfusion	8
9.	Connection of the Chamber with XY stage	9
10.	Cleaning	10

1. Components and dimensions

H301-MINI includes the following components:

- Chamber main body with embedded temperature sensor
- Heated glass lid with Indium Tin Oxide (ITO) conductive coating and embedded temperature sensor

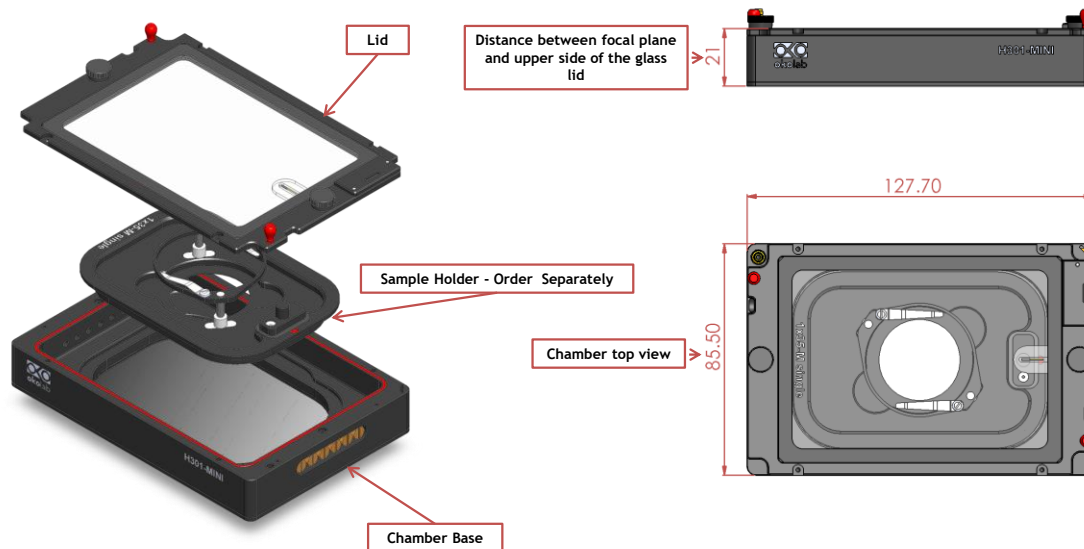

Figure 1. H301-MINI - Components and Dimensions.

2. Sample Holders

2.1 Available Sample Holders

The following sample holders are available.

NOTE: Please contact info@oko-lab.com if you cannot find the sample holder you are looking for. We are constantly adding new inserts to the list.

1x35-M single	#1 35mm Petri-dish
1xGS-M single	#1 1x3in. chamber slide
1xLABTEK-M single	#1 Lab-Tek 1in.x2in. chambered cover glass
1xLABTEK-II-M single	#1 Lab-Tek II 1in.x2in. chambered cover glass
1x60-M-single	#1 60mm Petri-dish



Figure 2. Available sample holders.

3. Insertion of the Sample Feedback Temperature Sensor

Insert the Sample Feedback Temperature Sensor through the dedicated opening located in the H301-MINI (see Figure 3, Frontal and 3D views).

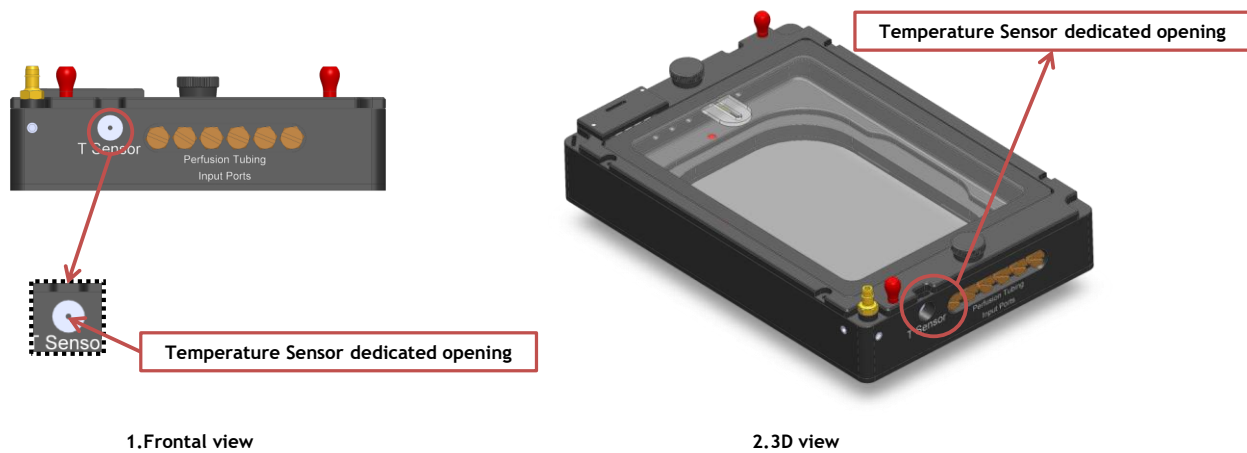

Figure 3. Insertion of the temperature sensor inside the chamber

4. Insertion of Sample Holder into Chamber

Sample holders fit into the chamber base and are held in place by magnets embedded within both chamber and holder. To introduce a sample holder with the proper orientation, match the red dot on the holder to the one on the chamber base, as illustrated in Figure 4.



Figure 4. Introduction of the Specimen Holder inside the Chamber Base.

5. Working with 35 or 60 mm Petri Dish – Spacing Rings and Magnetic Locks

Magnetic locks prevent movement of 35 and 60 mm dishes inside the sample holder.

Figure 5 illustrates the available magnetic locks for 35 and 60 mm dishes. Threaded magnetic posts allow adjusting holder's height.

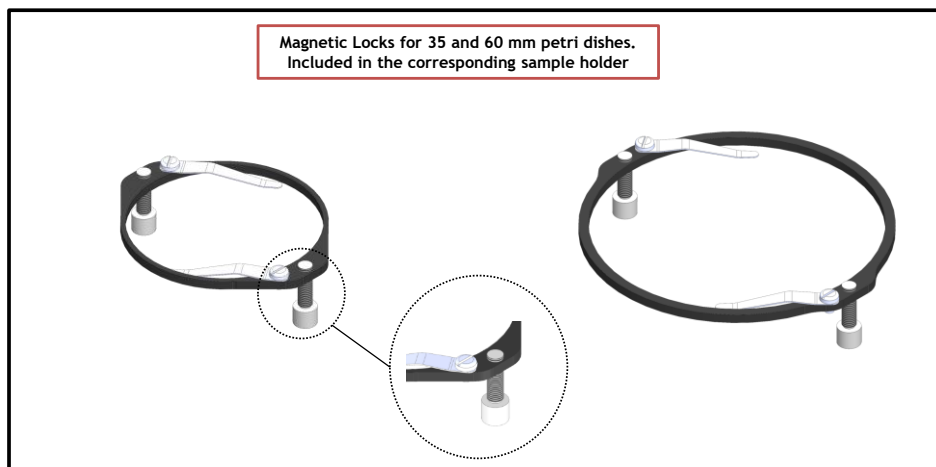

Figure 5. Magnetic locks for 35 and 60 mm dish

NOTE: Magnetic locks are included with sample holder.

Spacing rings accounting for variability in dish diameter from one manufacturer to another are also included. Figure 6 shows how to position the ring. Ring selection guide diagrams: rings for 35 and 60 mm dish -Figure 7 and Figure 8, respectively.

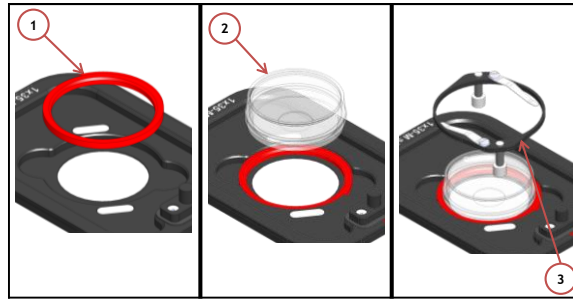

Figure 6. 1) Insertion of the ring, 2) insertion of the 35 mm dish, 3) insertion of the magnetic lock.

NOTE: Spacing rings are included with sample holder.

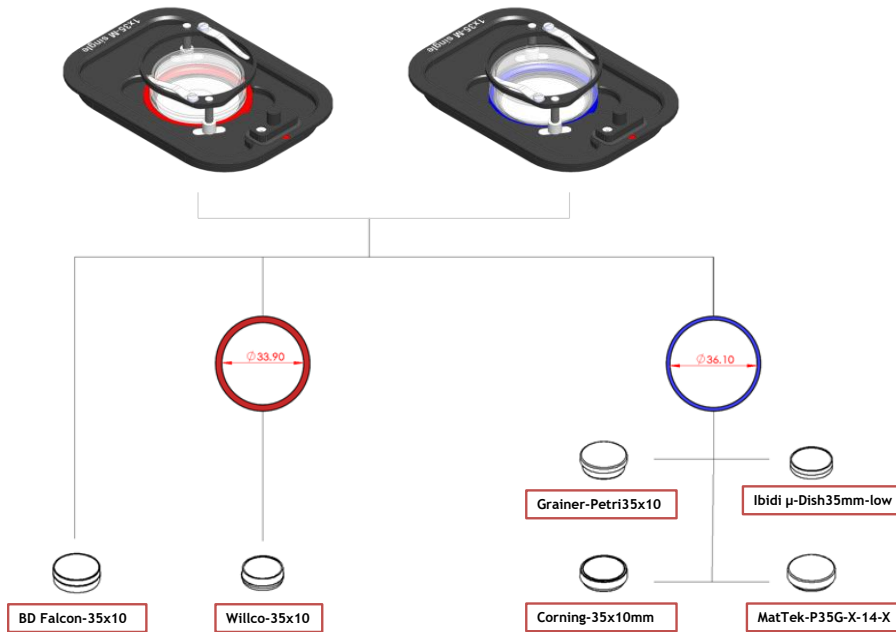

Figure 7. Ring selection scheme for 35 mm dish.

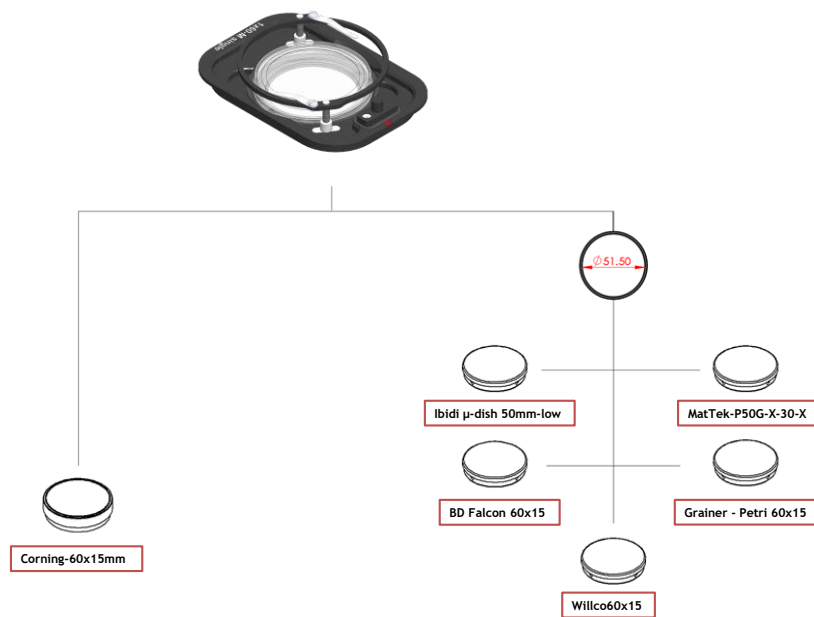

Figure 8. Ring selection scheme for 60 mm dish.

6. Working with 1x3'' and 1x2'' chamber slides - magnetic locks

Magnetic locks prevent movement of 1''x 3'' and 1''x 2'' chamber slides inside of the sample holder.

NOTE: Magnetic locks are included with sample holder.

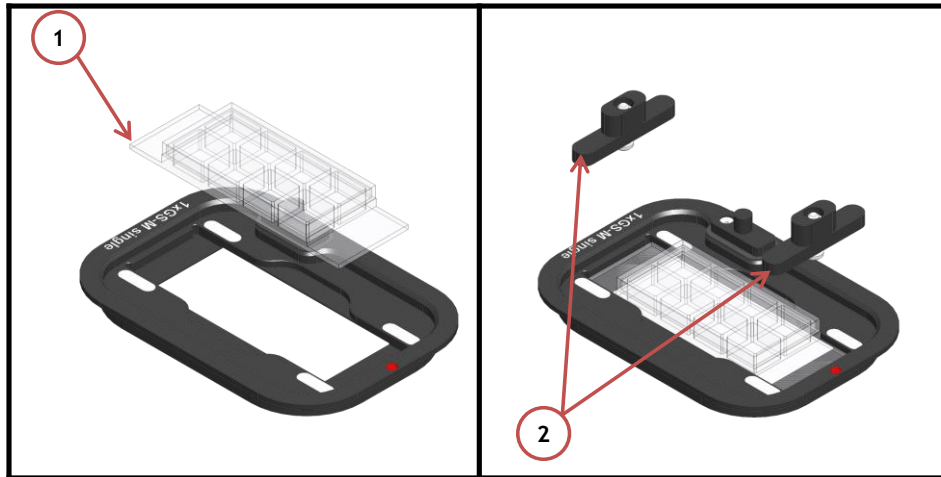

Figure 9. Magnetic lock for 1" x 3" chamber slide.

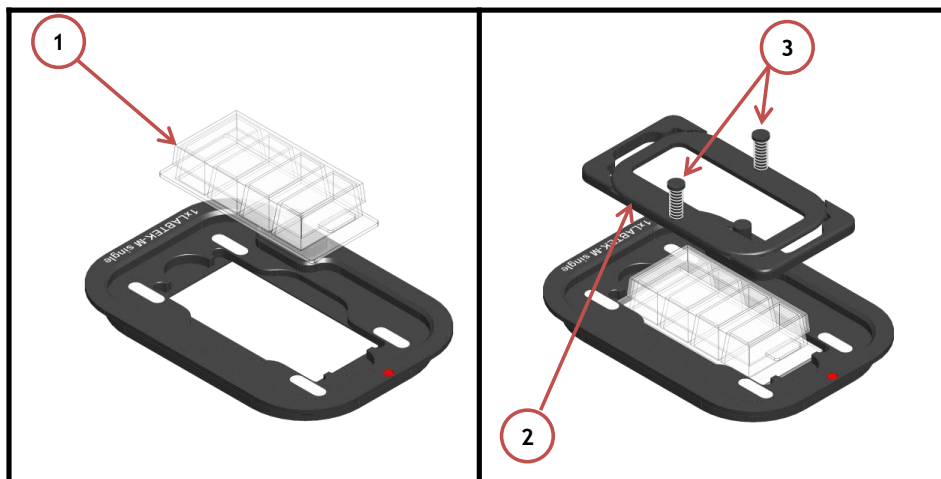

Figure 10. Magnetic lock for 1" x 2" chamber slide. To lock the slide, push simultaneously the buttons indicated with (3).

7. Connection of the Gas Supply

A single silicon tubing carries output gas from the Okolab Gas Controller to the H301-MINI. Silicon tubing connects to a gas input - brass opening - located on a corner of the H301-MINI. See Figure 11. Connect by gently pushing silicon tubing onto brass opening.

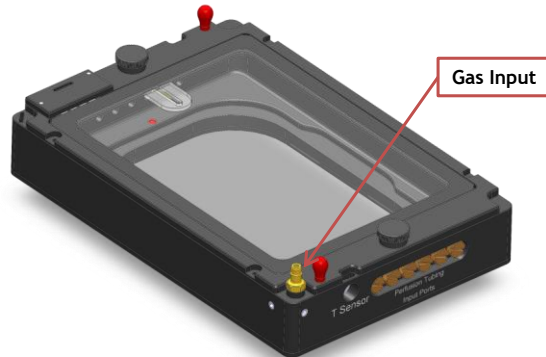

Figure 11. Connection with gas supply.

8. Working with Perfusion

The Chamber H301-MINI features 12 perfusion holes on the sides for the insertion of perfusion tubing up to 2.5 mm in outer diameter. Small screws plug the perfusion holes when not in use. (screws plug M3x0.5 THD). Remove small screws plug as necessary before introducing perfusion tubing.

Figure 12 shows location of perfusion holes.

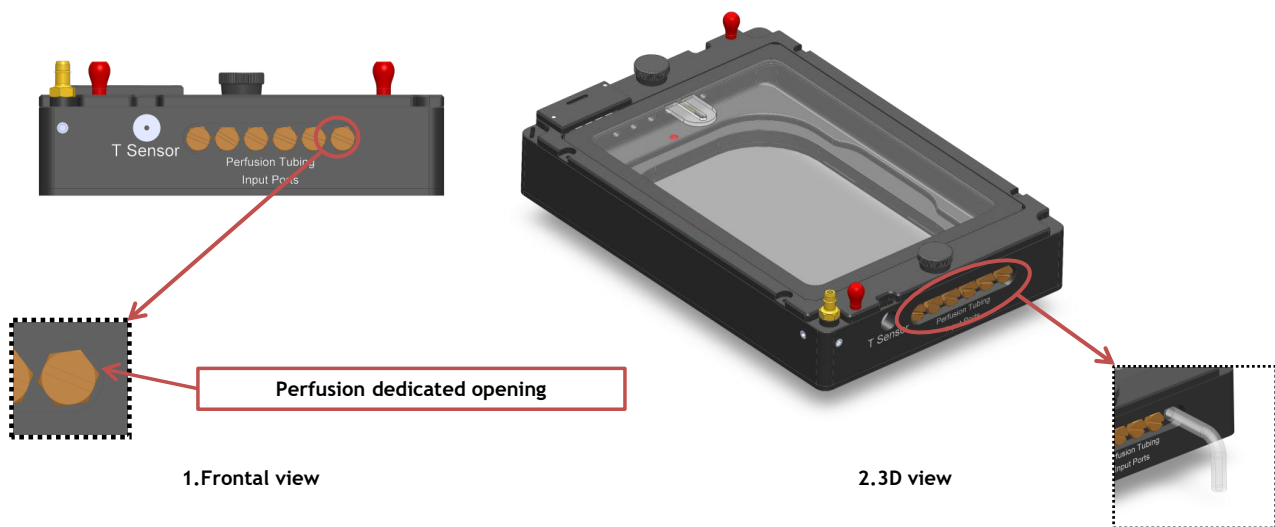

Figure 12. Perfusion

9. Connection of the Chamber with XY stage

H301-MINI fits on the XY Stage without any screws. To fix the chamber on the stage, follow the steps shown in Figure 13.

1. Place the chamber on the stage (See Image 1 of Figure 13).
2. Incline the chamber and slide it in direction of the springs until it snaps into the housing. (See Image 2 of Figure 13).
3. Image 3 of Figure 13 shows the chamber fitted on the XY Stage.

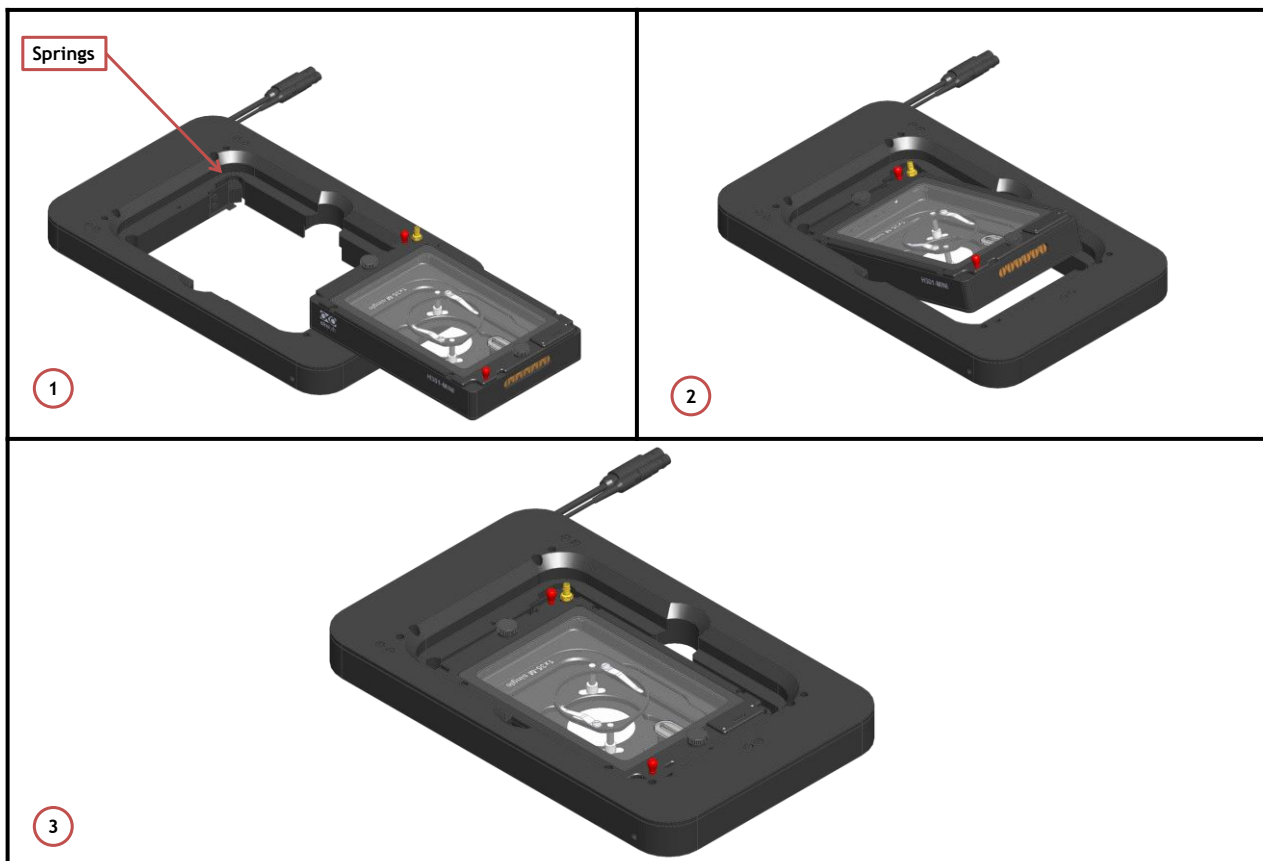

Figure 13. Connection of the Chamber with XY Stage

10. Cleaning

- Turn the system off and pull the mains plug out the socket
- Remove the lid from the chamber main body, and keep it separate from the chamber main body while the chamber cools down.
- To clean the body and the glass lid of the chamber, wipe with a soft micro-fiber cloth. For stubborn smudges, you can damp the soft micro-fiber cloth with ethyl alcohol (product code UN1170). Do not put any liquid directly on the chamber. While cleaning the glass lid, do not apply strong force to the surface of the glass lid because it can be damaged.