



## *H301-PI-736-ZR1S/ ZR2S*

H301-PI-736-ZR1S/ZR2S is compatible with the following Z-piezo stages: Physik Instrumente P-736-ZR1S/ZR2S and Prior PZ100.

IST 2150 \_REV01

## Index

1. Components and dimensions.....	3
2. Available Sample Holders.....	3
3. Installation .....	4
3.1 Working with Chamber Riser .....	4
3.2 Insertion of the Sample Holder into Chamber Main Body .....	4
3.3 Installation of the Chamber on the stage.....	5
3.4 Working with 35 Petri Dish- Spacing Rings and Magneti Locks .....	6
3.5 Working with 1”x3’’ and 1”x2’’chamber slides.....	7
3.6 Lid Assembly.....	8
4. Connection of the Gas Supply .....	9
5. Working with Perfusion .....	9
6. Insertion of the Sample Feedback Temperature Sensor.....	10
7. Cleaning .....	11

## 1. Components and dimensions

H301-PI-736-ZR1S/ZR2S includes the following components:

- Chamber Lid with Tin Oxide (ITO) conductive coating and embedded temperature sensor.
- Chamber riser. It is a removable frame increasing the height of the chamber from 22 to 27 mm.
- Sample Holder (to be ordered separately).
- Chamber main body with embedded temperature sensor.

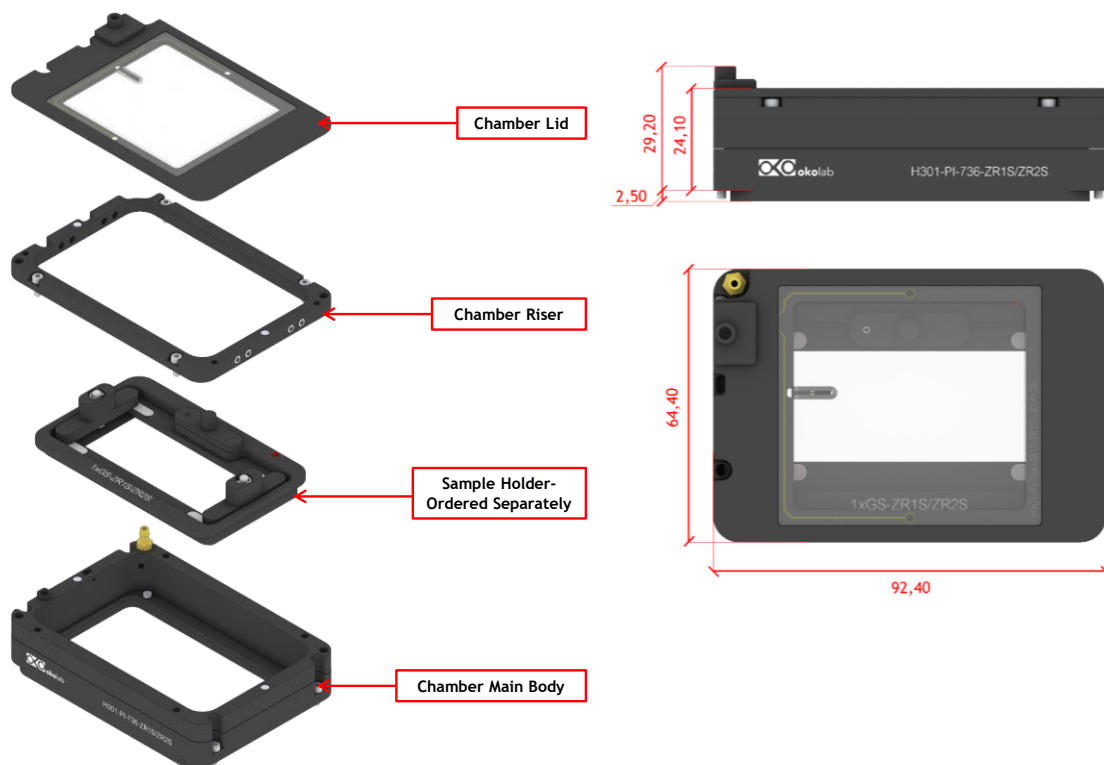

Figure 1. H301-PI-736-ZR1S/ZR2S. Components and Dimensions.

## 2. Available Sample Holders

The following sample holders are available.

**NOTE:** Please contact [info@oko-lab.com](mailto:info@oko-lab.com) if you cannot find the sample holder you are looking for. We are constantly adding new inserts to the list.

1x35-ZR1S/ZR2S	#1 35mm Petri-dish holder
1xGS-ZR1S/ZR2S	#1 1"x3" chamber slides slide holder
1xLABTEK-ZR1S/ZR2S	#1 Lab-Tek 1"x2" chambered cover glass holder
1xLABTEK-II-ZR1S/ZR2S	#1 Lab-Tek II 1"x2" chambered cover glass holder

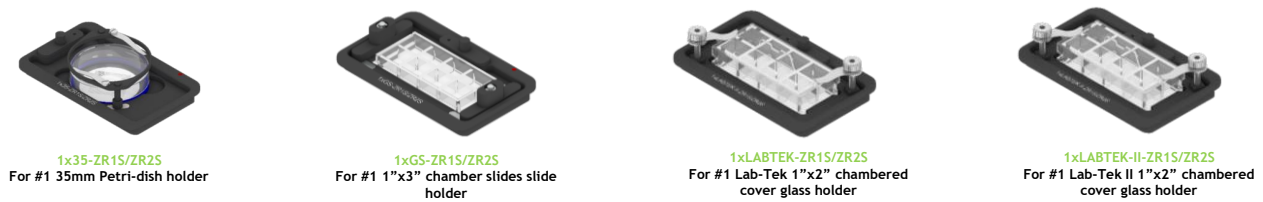

Figure 2. Available Sample Holders

### 3. Installation

Follow the instructions in the following paragraphs to install the chamber properly.

#### 3.1 Working with Chamber Riser

H301-PI-736-ZR1S/ZR2S includes the Chamber Riser, a removable frame increasing the height of the chamber from 22 to 27 mm. Figure 3 shows how to mount and screw the chamber riser. Fasten the four captive screws clockwise by using a 1.5 mm hexagonal key.

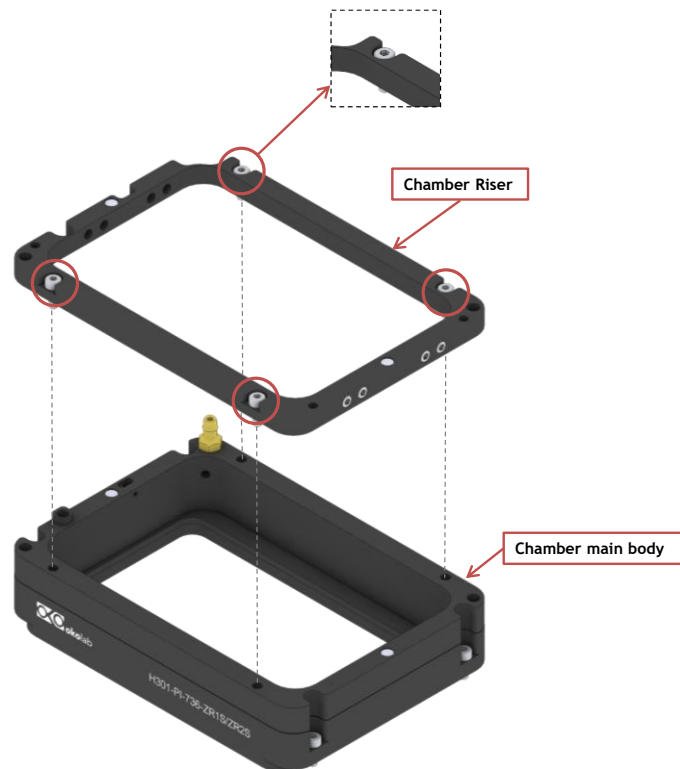

Figure 3. Chamber Riser Assembly

#### 3.2 Insertion of the Sample Holder into Chamber Main Body

Sample holders fit into the chamber main body and are held in place by magnets embedded within both chamber and holder. To introduce a sample holder with the proper orientation, match the red dot on the holder to the one on the chamber main body, as illustrated in Figure 4.



Figure 4. Introduction of the Sample Holder inside the Chamber main body.

### 3.3 Installation of the Chamber on the stage

To mount H301-PI-736-ZR1S/ZR2S chamber on the z piezo stage, follow the steps shown in Figure 5.

1. Slot the chamber main body into the stage, taking care to match the screws position (see 1 in Figure 5).
2. Fasten the four captive screws indicated by letter A using a 1.5 hexagonal key (see 3 Figure 5).

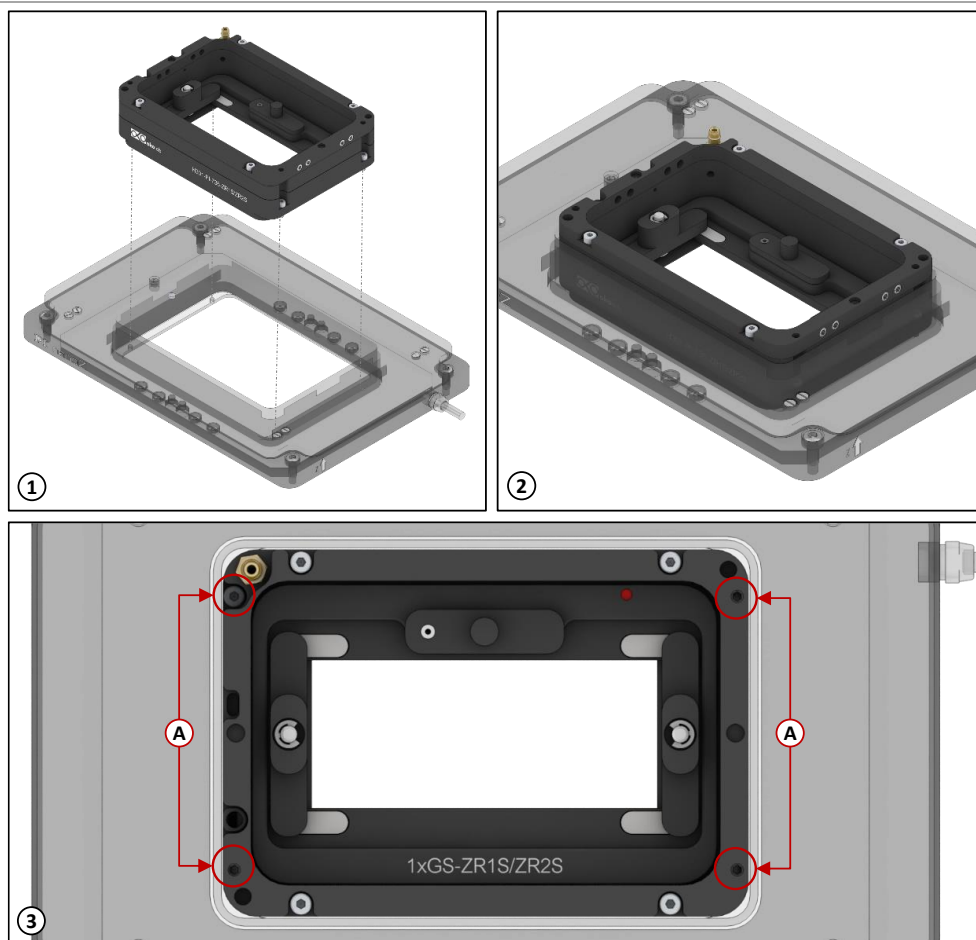

Figure 5. How to assemble the chamber on the stage.

### 3.4 Working with 35 Petri Dish- Spacing Rings and Magneti Locks

Magnetic lock, included with the sample holder, prevents movement of 35 mm dishes inside the sample holder (see Figure 6). Threaded magnetic posts allow adjusting holder's height.



Figure 6. Magnetic locks for 35 mm dish.

Spacing rings accounting for variability in dish diameter from one manufacturer to another are also included with the sample holder. Figure 7 shows how to position the ring and the magnetic lock. Ring selection guide diagrams for 35 mm dish in Figure 8.

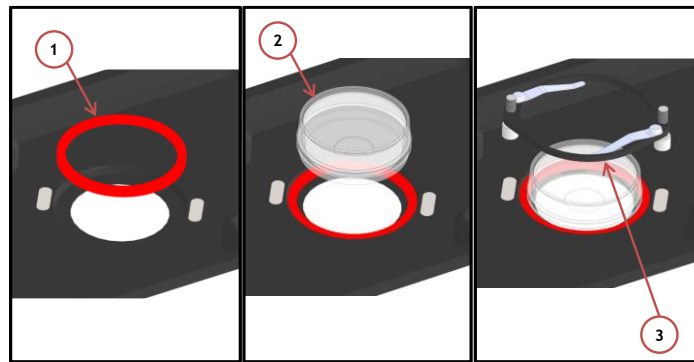

Figure 7. 1) Insertion of the ring, 2) insertion of the 35 mm dish, 3) insertion of the magnetic lock.

**NOTE:** Spacing rings do not block the petri inside its accommodation, but they are designed to center the petri with respect to the observation circular window.

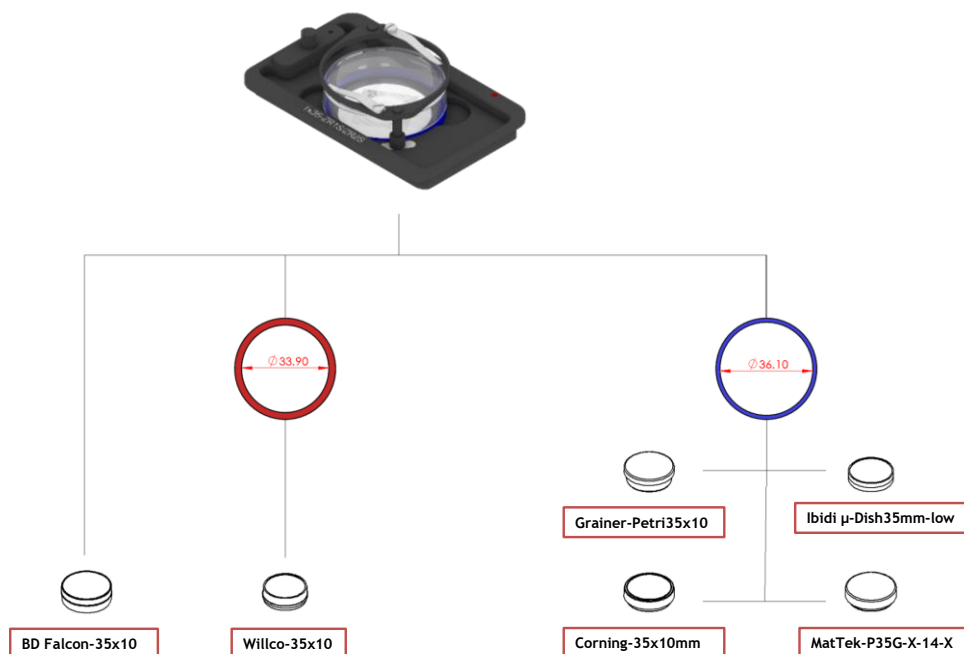

Figure 8. Generic ring selection scheme for 35 mm dish.

### 3.5 Working with 1"x3" and 1"x2" chamber slides

Magnetic locks prevent movement of 1"x 3" chamber slides inside of the sample holder, see Figure 9.

**NOTE:** Magnetic locks are included with sample holder.

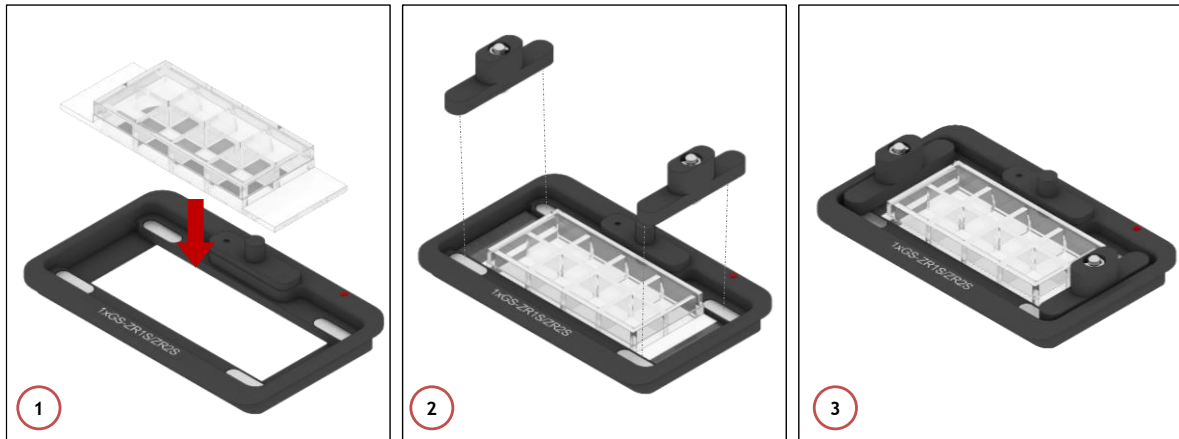

Figure 9. Sample holder for 1"x3" chambered cover glass holder.

Flat springs prevent movement of 1"x2" chamber slides inside of the sample holder, see Figure 10.

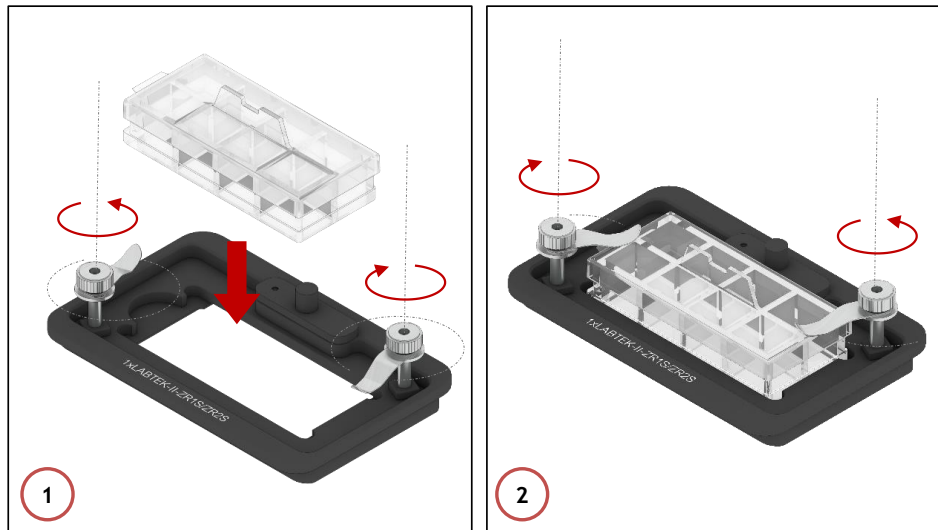

Figure 10. Sample holder for 1"x2" chambered cover glass holder.

### 3.6 Lid Assembly

Place the Lid on the chamber base (No screws or tools are necessary), see Figure 11.



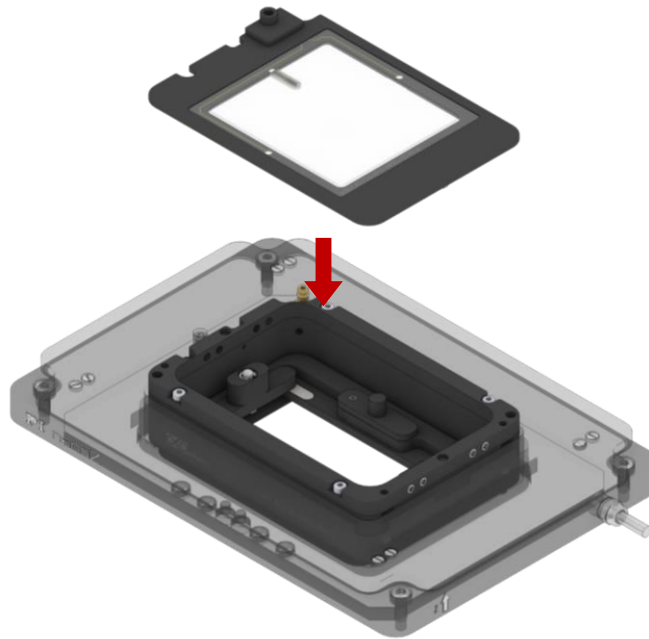

Figure 11. Lid Assembly.

## 4. Connection of the Gas Supply

A single silicon tubing carries output gas from the Okolab Gas Controller to the H301-PI-736-ZR1S/ZR2S. Silicon tubing connects to a gas input - brass opening - located on a corner of the H301-PI-736-ZR1S/ZR2S. See Figure 12. Connect by gently pushing silicon tubing onto brass opening.



Figure 12. Connection with gas supply.

## 5. Working with Perfusion

The Chamber Riser included with H301-PI-736-ZR1S/ZR2S features 8 perfusion holes for the insertion of perfusion tubing up to 2.5 mm in outer diameter. Small screws plug the perfusion holes when not in use. (Grub screws M3x6). Remove small screws as needed before introducing perfusion tubing.

Figure 13 shows location of perfusion holes.

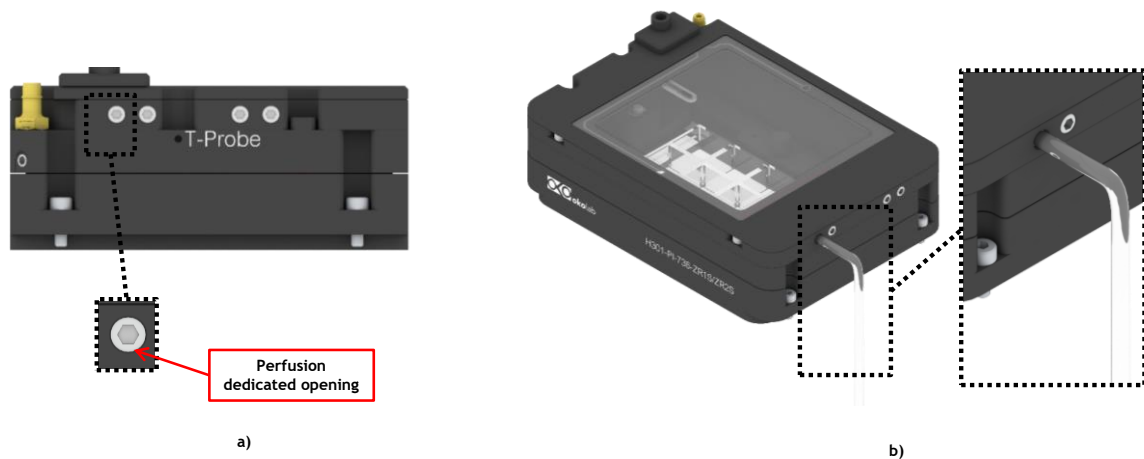

Figure 13. Perfusion (a - b).

## 6. Insertion of the Temperature Sensor

If you operate in Chamber Feedback mode, to realize a self-calibration of H301-PI-736-ZR1S/ZR2S, insert the Temperature Sensor through the dedicated opening located in the chamber main body (see Figure 14, a) and fix the Temperature Sensor with adhesive tape on the bottom of the dish (see Figure 14, b). Do not cover the tip with the adhesive tape.

For more information about the self-calibration, please refer to the User Manual of the Okolab Controller.

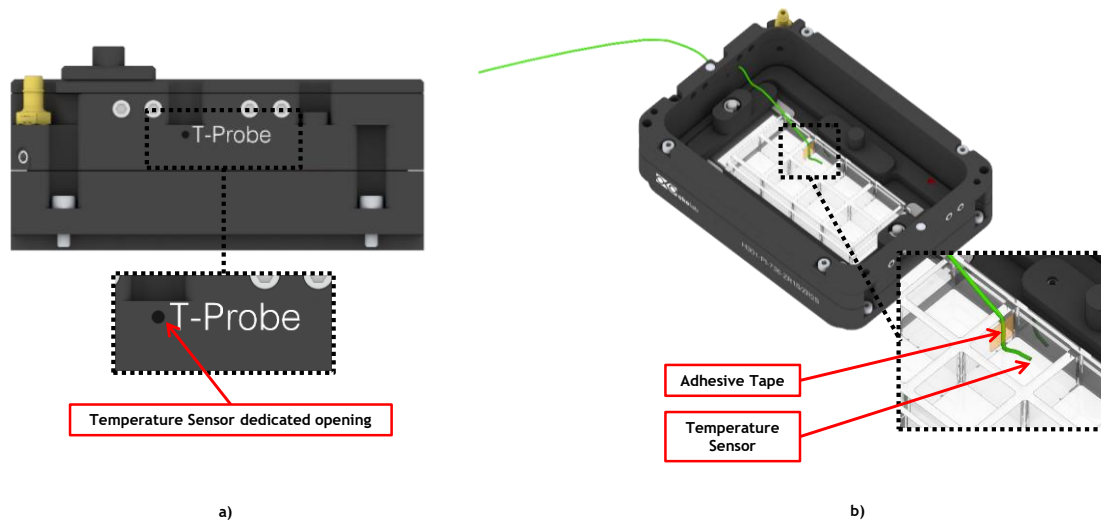

Figure 14. Insertion of the temperature sensor inside the chamber (a - b).

If you operate in Sample Feedback mode, insert the Temperature Sensor in the Reference Well (see Figure 15). Remove the Reference Well cover and fill the Reference Well with water. Place the Reference Well cover on the Reference Well. Make sure that the cover is firmly plugged.

Insert the Temperature Sensor Tip in the dedicated hole of the Reference Well and make sure that the Temperature Sensor Tip is fully immersed.

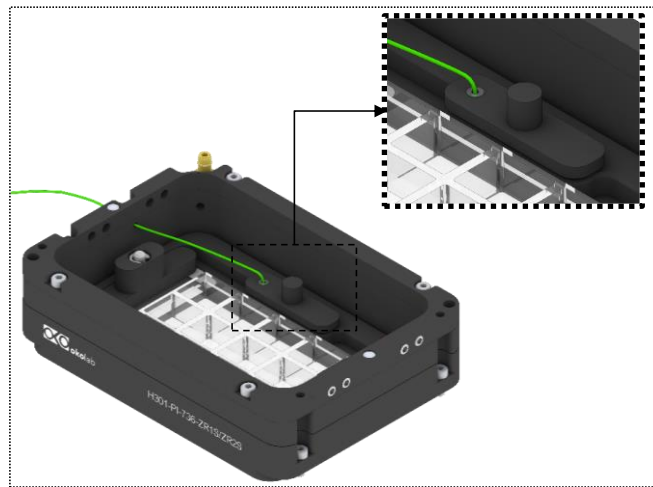

Figure 15. Insertion of the temperature sensor inside the Reference Well.

## 7. Cleaning

- Turn the system off and pull the mains plug out the socket
- Remove the lid from the chamber main body, and keep it separate from the chamber main body while the chamber cools down.
- To clean the body and the glass lid of the chamber, wipe with a soft micro-fiber cloth. For stubborn smudges, you can damp the soft micro-fiber cloth with ethyl alcohol (product code UN1170). Do not put any liquid directly on the chamber. While cleaning the glass lid, do not apply strong force to the surface of the glass lid because it can be damaged.